

#### Features

#### Releasing control using the Simplex® 4010ES Fire Alarm Control Unit to provide:

- Coverage for multiple areas of Automatic Extinguishing Release and/or Deluge and Preaction Sprinkler System Release including audible escalation of events
- Control of compatible Listed/Approved valves and actuators.
- Releasing appliance circuits (RACs) by connecting Notification appliance circuits (NACs) to Suppression Release Peripherals for actuator supervision and control
- Four, 3 Amp Notification Appliance Circuits (NACs) in the control unit for use with Suppression Release Peripherals (SRP) and required notification appliances
- Additional actuator circuit control and additional NACs are available using 4009 IDNet Addressable NAC Extenders and Suppression Release Peripherals

#### Audible Escalation of Events:

- Temporal or 20 bpm March Time pattern for first cross-zone alarm
- 120 bpm March Time pattern indicates releasing timer active
- On steady indicates releasing timer expired and actuator is activated
- NOTE: Requires NACs dedicated to conventional horn control (not SmartSync operation) with strobes controlled on separate NACs

#### 4009 IDNet NAC Extenders provide:

- Up to eight NACs for notification requirements and for NAC input to Suppression Release Peripherals
- Control is via IDNet addressable communications

#### 4090-9005/9006 Suppression Release Peripheral (SRP) with Dual Input Control Logic:

- Dual input control logic requires that both IDNet communications commands and an activated NAC are present to initiate the desired release
- Releasing Appliance Circuit (RAC) output provides wiring supervision to the actuator including monitoring of coil continuity and short circuit supervision to the coil supervision module

#### Suppression Release Peripheral control features:

- An on-board DC-DC regulator compensates for voltage drops to the peripheral and ensures proper control circuit voltage over a wide operating range
- Provides a single RAC for control of actuators for up to 2 A using a 3 A NAC input (1 A using a 2 A NAC input)

#### Related system components:

- 4010ES Series control unit with Releasing Appliqué
- Dedicated NAC output from 4010ES (or compatible NAC Extender)
- Coil supervision module, one per RAC
- Maintenance Switch, one per RAC
- Abort Switch connected via an addressable interface module

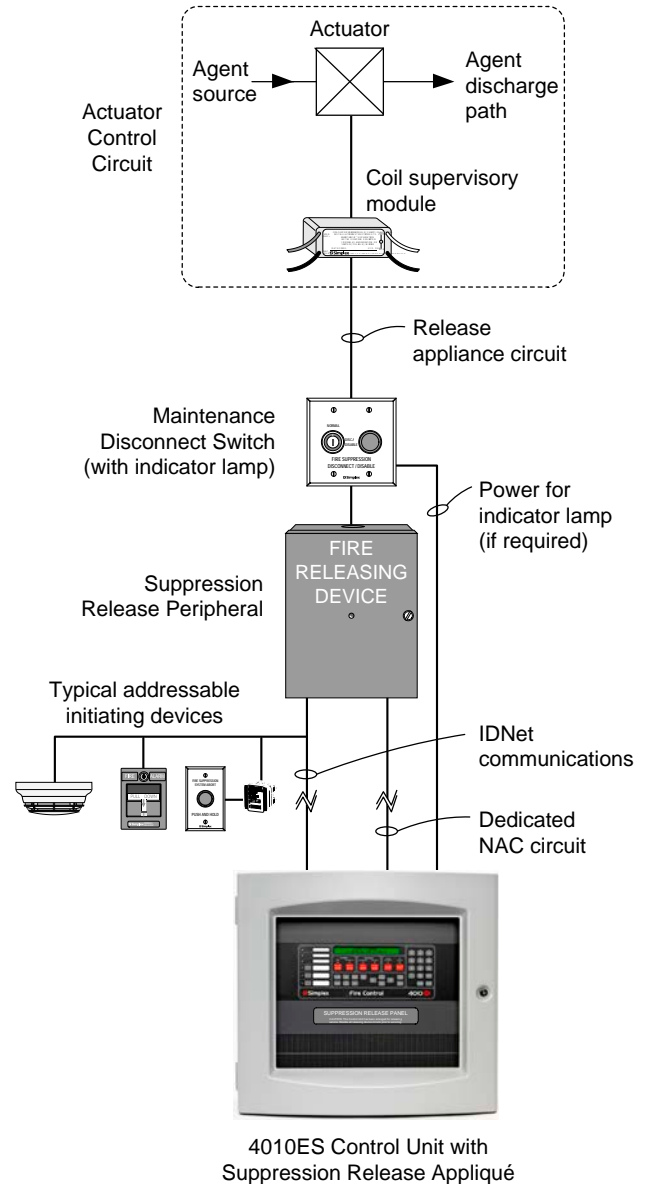

4010ES Release Control Simplified Block Diagram

#### Introduction

When combined with Suppression Release Peripherals, the 4010ES series Fire Alarm Control Unit provides actuator supervision and control for use in automatic extinguishing, and deluge or preaction releasing systems. Hazard area initiating and notification devices are controlled using either conventional or addressable circuits per standard 4010ES capabilities. The necessary releasing system logic is implemented within the 4010ES control unit as required for the local application.

\* Additional listings may be applicable; contact your local Simplex product supplier for the latest status. Listings and approvals under Simplex Time Recorder Co. are the property of Tyco Fire Protection Products.

## Automatic Extinguishing Release Systems

These systems automatically activate electrically controlled actuators for the release of a fire extinguishing agent (such as dry chemical, water spray, foam, CO<sub>2</sub>, or clean agent) in response to fire detection device inputs as determined by programming of the host fire alarm control unit.

**Automatic Extinguishing Release Systems** are required to have a minimum of 24 hours of standby power. Initiating devices must be Listed/Approved for the application, and may be wired either Class A or B. Control actuators must be electrically compatible with the control unit circuits and power supplies, and are wired Class B to provide coil supervision.

### 4010ES Agency listings

- UL 864 - Control Units, System (UOJZ); Control Unit Accessories, System, Fire Alarm (UOXX); Control Units, Releasing Device Service (SYZV); Smoke Control System Equipment (UUKL)
- UL 1076 - Proprietary Alarm Units (APOU)
- UL 1730 - Smoke Detector Monitors and Accessories (UULH)
- UL 2017 - Emergency Alarm System Control Units, CO detection (FSZI); Process Equipment Management (QVAX)
- ULC-S527 - Control Units, System, Fire Alarm (UOJZC); Control Unit Accessories, System, Fire Alarm (UOXXC); Control Units, Releasing Device Service (SYZVC); Smoke Control System Equipment (UUKLC)
- ULC-S559 - Central Station Fire Alarm System Units (DAYRC)
- CSA 6.19 - Gas Alarms and Accessories (CZHFC)
- ULC/ORD-C1076 - Proprietary Burglar Alarm System Units (APOUC)
- ULC/ORD-C100 - Smoke Control System Equipment, UUKLC

### Deluge or Preaction Sprinkler Systems

These systems automatically activate water control actuators in response to fire detection device inputs.

**Deluge Sprinkler Systems** employ open sprinkler heads and provide water flow when the fire detection system activates a common automatic water control actuator. They are used to deliver water simultaneously through all of the system sprinkler heads. This type of system is applicable where the immediate application of large quantities of water over large areas is the proper fire response.

**Preaction Sprinkler Systems** are similar to deluge systems except that normally closed sprinkler heads are used and supervisory air pressure is maintained in the pipe. Operation requires both an activated sprinkler head and an activated fire alarm initiating device with specific programming determined at the host fire alarm control unit.

## Releasing System Requirements

1. **Releasing actuators** are controlled from a Suppression Release Peripheral (4090-9005 or 4090-9006). Connections are 2-wire, Class B releasing circuits **with only one 24 VDC actuator per circuit**. Where applicable, two, 12 VDC actuators in series, or one 12 VDC actuator per circuit may be used (refer to the actuator manufacturer's installation documentation for additional details and requirements).
2. **Coil Supervision Module 2081-9046** must be wired electrically before the actuator and located in the actuator wiring junction box. (Refer to diagram on page 5.) The connected RAC provides continuity supervision of the actuator coil and wiring and provides short circuit supervision to the coil supervision module.
3. **Cross-zoning or other alarm initiation logic** per system requirements, is to be implemented by programming at the fire alarm control unit.
4. **UL Listed Automatic Extinguishing Releasing operation** requires that: battery standby must be a minimum of 24 hours with 5 minutes of alarm and that listed actuators are used, refer to list on page 6.
5. **FM Approved Automatic Extinguishing Release** requires secondary standby to be a minimum of 24 hours with 5 minutes of alarm. Actuators must be electrically compatible.
6. **FM Approved Deluge and Preaction Sprinkler operation** requires that: initiating device circuits be Class A and wired to Listed/Approved devices; standby power capacity must be a minimum of 90 hours with 10 minutes of alarm; and that compatible Automatic Water Control Valves must be used. (Refer to actuator list on page 7.)
7. **Maintenance Switches**, one per RAC, are required per NFPA 72, the *National Fire Alarm and Signaling Code* to allow the system to be tested or serviced without actuating the fire suppression systems. *Their use may not be allowed in some jurisdictions, always confirm local requirements.* When used, Simplex Maintenance Switches are required to ensure that operation initiates a supervisory condition.
8. **Abort Switches** are available when abort operation is required. When used, connect to an addressable Supervised IAM model 4090-9001 or similar addressable adapter module. The Simplex abort switch and the IAM mount in a single gang box, 2-1/2" minimum depth.
9. **Addressable Manual Releasing Stations** are used to initiate activation of the releasing actuators with the appropriate time delay implemented by the fire alarm control unit.
10. **Notification Requirements.** Each hazard area typically requires general audible and visible fire alarm notification and additional dedicated NACs for area releasing status notification.
11. **The IDNet Suppression Release Peripheral (SRP)** required for release control requires two inputs; IDNet and a dedicated NAC input. For additional SRP reference refer to installation instructions 579-385.

## Additional Releasing Systems Reference

For additional information, refer to Factory Mutual Research Corporation (FMRC) “FMRC Approval Guide,” FM Approval standard “Automatic Releases for Preaction and Deluge Sprinkler Systems.” Please note that proper operation of releasing control systems requires that the system design, installation, and maintenance be performed correctly and in accordance with all applicable local and national codes, and equipment manufacturer’s instructions. No liability for total system operation is assumed or implied.

## Product Selection

### 4010ES Releasing Control System Modules

Model	Description		Reference
2081-9046	Coil Supervision Module		<b>Required</b> , one per RAC, mounts in the releasing actuator wiring junction box; see specifications section for details
2080-Series*	Maintenance Switches		One per RAC; flush or surface mount; indicator lamp models require separate 24 VDC wiring
2080-9056*	Flush mount	Abort Switch	As required, connects via an IDNet addressable interface module; mounted on a single gang stainless steel plate; installation requires a single gang box, 2-1/2" (64 mm) minimum depth
2080-9057*	Surface mount		

\* Refer to data sheet S2080-0010 for Abort and Maintenance switch details.

### Releasing Appliqués, Required for 4010ES Suppression Releasing Applications

Model	Description	
4010-9830	English	Suppression Releasing Appliqué; field applied (same appliqué as is used on the Simplex model 4010 Suppression Release Control Unit)
4010-9830CAF	French	

### Suppression Release Peripheral and Accessories

Model	Description	Reference
4090-9005	Basic Suppression Release Peripheral on mounting plate	Requires mounting box 2975-9227, ordered separately
4090-9006	Suppression Release Peripheral mounted in NEMA 1 red box; required for ULC listing	Includes LED indicator on front of door
2975-9227	NEMA 1 red mounting box; required for 4090-9005	These items are included with model 4090-9006
4090-9812	Red LED IDNet communications indicator option kit; mounts on door of 2975-9227 box	

## Additional Product Reference

Subject	Data Sheet
Releasing System Abort and Maintenance Switches	S2080-0010
4009 IDNet NAC Extender	S4009-0002
4010ES Panels with Conventional Notification (INTL)	S4010-0006
InfoAlarm Command Center for the 4010ES Panels (INTL)	S4010-0009
4010ES Panels with Addressable Notification (INTL)	S4010-0012
Addressable Manual Stations for Releasing Applications	S4099-0006

# 4010ES Conventional NAC Panel Releasing System One-Line Connection Reference

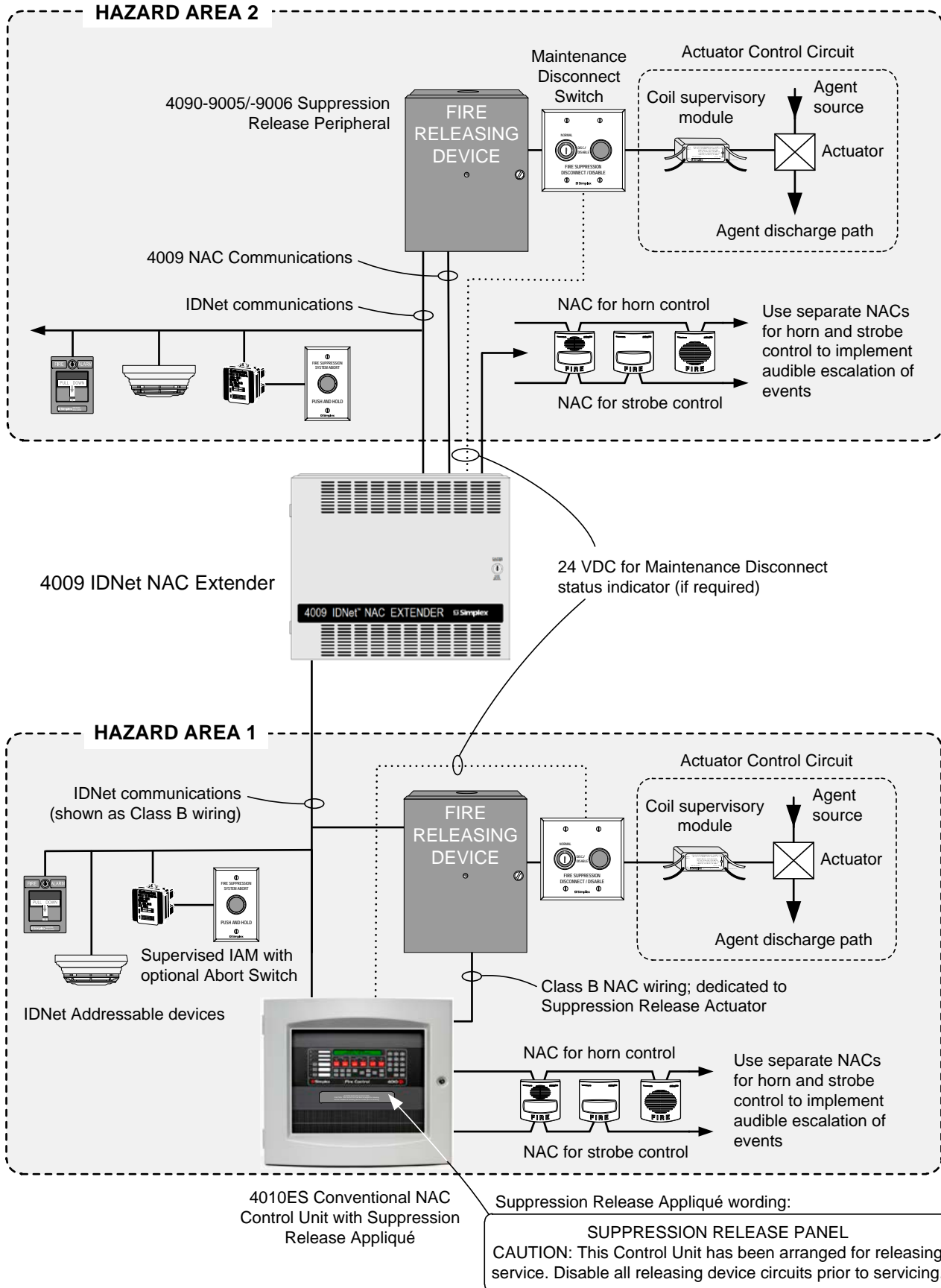

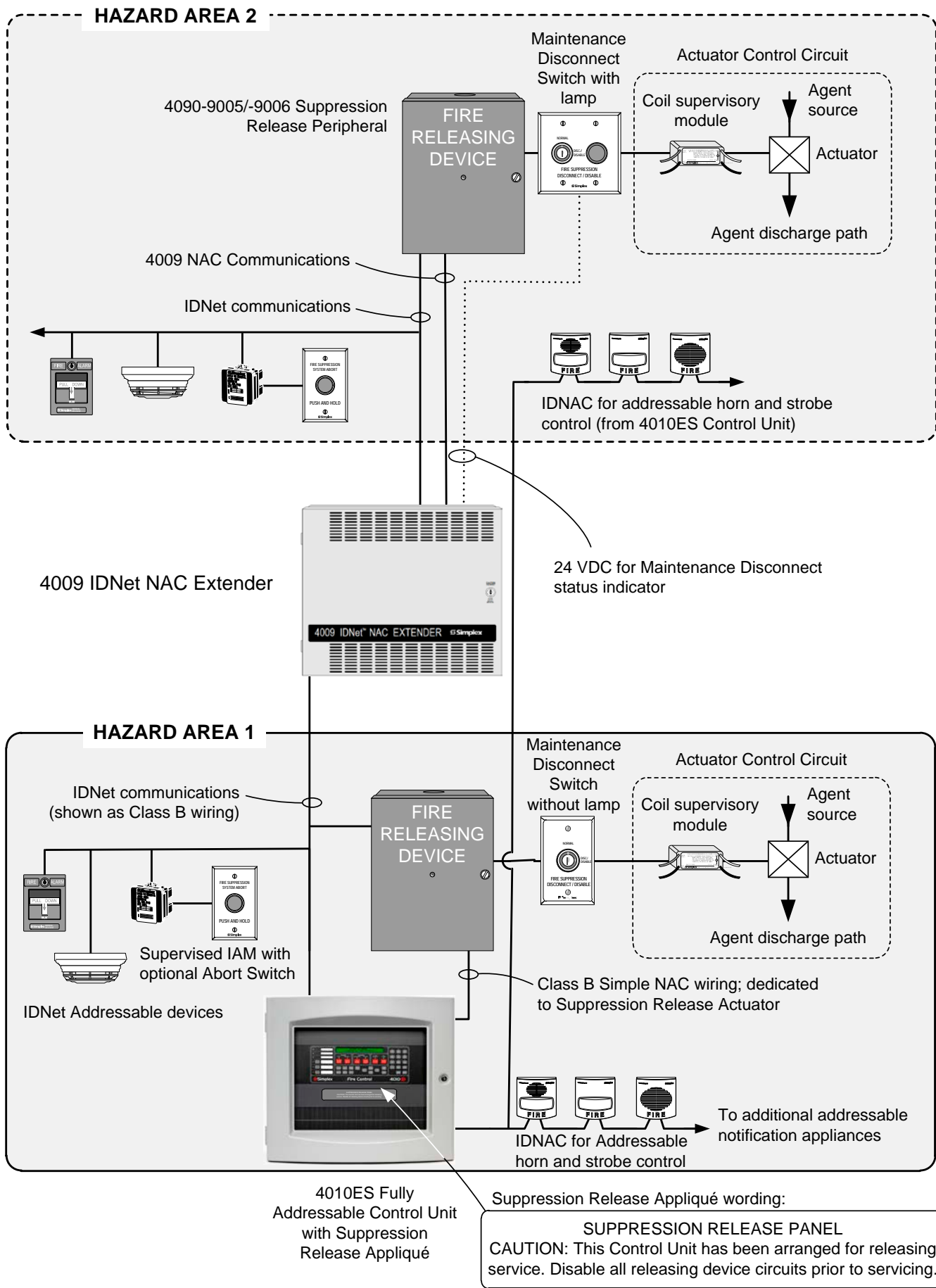

# Suppression Release Peripheral Wiring Reference

**Maximum Release Appliance Circuit (RAC) Wiring Distances from Suppression Release Peripheral to the Valve Solenoid** (based on a total drop of 0.6 V)

RAC Output Current (refer to solenoid rating)	Distance								Total Line Resistance
	18 AWG		16 AWG		14 AWG		12 AWG		
0.50 A	74 ft	23 m	118 ft	36 m	188 ft	57 m	300 ft	91 m	1.06 Ω
0.75 A	50 ft	15 m	79 ft	24 m	126 ft	38 m	200 ft	61 m	0.71 Ω
1.00 A	37 ft	11 m	59 ft	18 m	94 ft	29 m	150 ft	46 m	0.53 Ω
1.25 A	30 ft	9 m	47 ft	14 m	75 ft	23 m	120 ft	36.6 m	1.06 Ω
1.5 A	25 ft	7.6 m	39 ft	12 m	63 ft	19 m	100 ft	30.5 m	0.71 Ω
1.75 A	21 ft	6.4 m	34 ft	10 m	54 ft	16 m	85 ft	26 m	0.53 Ω
2.00 A	19 ft	5.8 m	30 ft	9 m	47 ft	14 m	75 ft	23 m	0.53 Ω

Metric wire equivalents: 18 AWG = 0.82 mm<sup>2</sup>; 16 AWG = 1.31 mm<sup>2</sup>; 14 AWG = 2.08 mm<sup>2</sup>; 12 AWG = 3.31 mm<sup>2</sup>

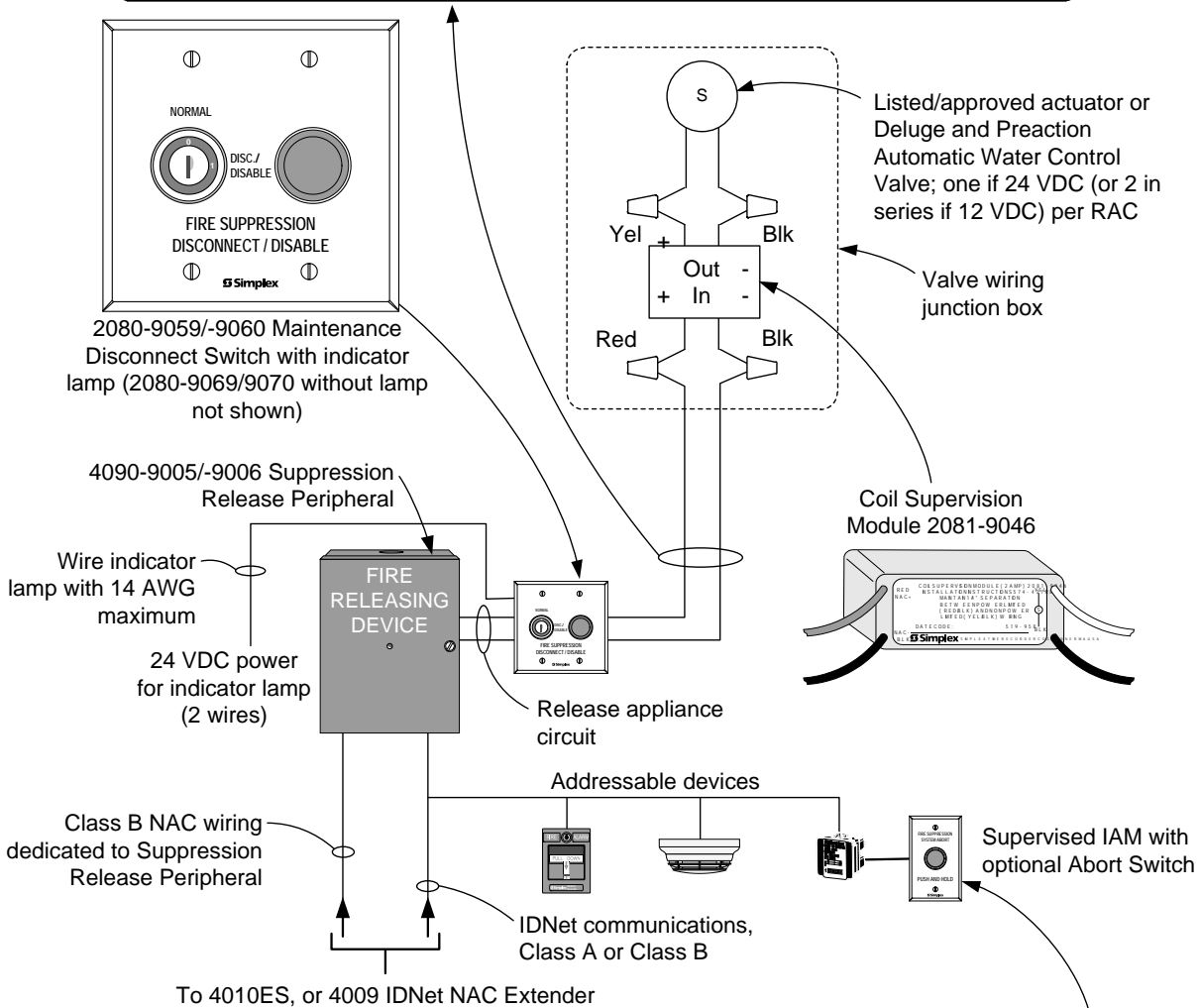

**Maximum Notification Appliance Circuit (NAC) Wiring Distances to a Suppression Release Peripheral** (0.5 A to 1.75 A drop is based on a total drop of 3.4V; 2 A drop is based upon a total drop of 1.2 V)

RAC Output Current (refer to solenoid rating)	Distance								Total Line Resistance
	18 AWG		16 AWG		14 AWG		12 AWG		
0.50 A	250 ft	76 m	399 ft	122 m	635 ft	194 m	1010 ft	308 m	3.58 Ω
0.75 A	167 ft	51 m	266 ft	81 m	423 ft	129 m	673 ft	205 m	2.39 Ω
1.00 A	125 ft	38 m	199 ft	61 m	317 ft	97 m	505 ft	154 m	1.79 Ω
1.25 A	100 ft	30 m	159 ft	48 m	254 ft	77 m	404 ft	123 m	1.43 Ω
1.5 A	84 ft	26 m	133 ft	41 m	212 ft	65 m	337 ft	103 m	1.19 Ω
1.75 A	72 ft	22 m	114 ft	35 m	181 ft	55 m	289 ft	88 m	1.02 Ω
2.00 A	25 ft	7.6 m	39 ft	12 m	63 ft	19 m	100 ft	30 m	0.36 Ω

Metric wire equivalents: 18 AWG = 0.82 mm<sup>2</sup>; 16 AWG = 1.31 mm<sup>2</sup>; 14 AWG = 2.08 mm<sup>2</sup>; 12 AWG = 3.31 mm<sup>2</sup>

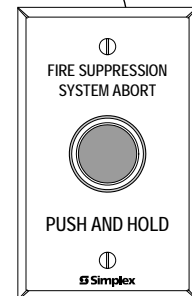

## Specifications

### Suppression Release Peripheral 4090-9005 and 4090-9006

Communications		IDNet, one address			
RAC Output Rating	with 4010ES	2 A maximum	At nominal 24 VDC, regulated; refer to NAC Power Requirements for more detail		
	with 4009 IDNet NAC Extender	1 A maximum			
NAC Power Requirements	Voltage	16 to 32 VDC (nominal 24 VDC)			
	Supervisory Current	No additional current required, circuit appears as standard end-of-line (EOL) NAC loading			
	Alarm Current Reference  (RAC current = actuator current)	<b>RAC Current</b>	<b>NAC Current</b>	<b>RAC Current</b>	<b>NAC Current</b>
		0.5 A	0.845 A	1.25 A	2.14 A
		0.75 A	1.28 A	1.5 A	2.56 A
0.87 A		1.5 A	1.75	3 A	
1 A	1.71 A	2 A			
Wire Connections		Screw terminals for input and output wiring, 18 to 12 AWG wire (0.82 mm <sup>2</sup> to 3.31 mm <sup>2</sup> )			
IDNet Wiring Distance Reference		Up to 2500 ft (762 m) from the IDNet source module			
		Up to 10,000 ft (3048 m) total Class B wiring distance including T-Taps			
		Compatible with Simplex 2081-9044 Overvoltage Protectors			
Dimensions		See installation reference on page 8			
Operating Temperature		32° to 120° F (0° to 49° C) indoor operation only			
Operating Humidity Range		10 to 90% RH at 90° F (32° C)			

### Coil Supervision Module 2081-9046

Construction	Epoxy encapsulated
Dimensions	1-3/8" W x 2-7/16" L x 1-1/16" H (34 mm x 62 mm x 27 mm)
Wiring	18 AWG (0.82 mm <sup>2</sup> ) wire leads, color coded
Current Rating	2 A Maximum; internally fused at 3 A, non-replaceable

## Compatible UL Listed Valves and Actuators

Manufacturer	Model Number	Electrical Ratings
ANSUL	AUTOMAN II-C Assembly (solenoid 17728; coil 25924)	24 VDC, 750 mA
	AUTOMAN II-C Explosion-Proof Releasing Device (solenoid 31492; coil 31438)	24 VDC, 750 mA
	AUTOMAN II-C Assembly (solenoid 68739; coil 25924)	24VDC, 750 mA
	Solenoid Electric Actuator (solenoid 73111; coil 73097)	24 VDC, 1 A
	*CV90 HF Electric Actuator 73327	24 VDC, 570 mA
	LP CO2 w/ASCO solenoid 422934	24 VDC, 442 mA
	LP CO2 double action 24 VDC solenoid 430948	24 VDC, 438 mA
	LP CO2 3-way selector valve solenoid 433419	24 VDC, 438 mA
	Electric Actuator 24 VDC solenoid 570537	24 VDC, 250 mA
LPG	Solenoid Electric Actuator (uses solenoid: Flow Control 609500/671S) Solenoid Coupling Assembly 21006401 (uses solenoid: Flow Control 609500/671S) Solenoid Coupling Assembly 21006402 (uses solenoid: Flow Control 609500/671S) LPG128/145/190/230-50/55 FM-200 valves (uses solenoid: Flow Control 609500/671S) LPG128-90UL iFLOW and FM-200 valve (uses solenoid: Flow Control 609500/671S)	24 VDC, 542 mA
Skinner	71395SN2ENJ1NOH111C2 (Skinner coil H111C2)	24 VDC, 420 mA
	73212BN4TN00NOC111C2 (Skinner coil C111C2)	24 VDC, 420 mA
	73212BN4TNLVNOC322C2 (Skinner coil C322C2)	24 VDC, 830 mA
	73218BN4UNLVNOH111C2 (Skinner coil H111C2)	24 VDC, 410 mA
	73218BN4UNLVNOC111C2 (Skinner coil C111C2)	24 VDC, 410 mA
ASCO	8210A107 (097617-005D coil)	24 VDC, 750 mA
	8210G207 (238310 coil)	24 VDC, 440 mA
	8211A107 (097617-005D coil)	24 VDC, 750 mA
	8262H182 (238910 coil)	24 VDC, 483 mA
	HV2628571 (23810 coil)	24 VDC, 442 mA
	HV2648581 (23810 coil)	24 VDC, 442 mA
	EF8210G001MBMO (238714 coil)	24 VDC, 450 mA
	R8210A107 (097617-005D coil)	24 VDC, 700 mA
	T8210A107 (097617-005D coil)	24 VDC, 700 mA
Pyro-Chem	ECH Electrical Control Head (551201)	24 VDC, 1700 mA
	Explosion-Proof Electric Actuator (570147)	24 VDC, 396 mA
	Removable Electric Actuator (570209)	24 VDC, 200 mA
Hygood	304.205.010 – Electrical Actuator Suppression Diode	24 VDC, 250 mA
	304.209.001 – Electrical Actuator Bridge Rectifier	24 VDC, 250 mA
Minimax	Model MX1230 without diode	24 VDC, 500 mA
Versa	CGS-4292-NB3-S20000	24 VDC, 438 mA
Burkert	5282 2/2-Way Solenoid Valve	24 VDC, 333 mA
Tyco Safety Products	TSP 304205030	24 VDC, 0.5 A
	TSP 304700001	24 VDC, 830mA
Masteco	MSC-01	24 VDC, 1.7 A

\* For 24 VDC, 450 mA activation, requires one actuator connected in series with a 73866 (21.5 ohm, 23 watt) in-line resistor shipping assembly ordered separately. For additional information refer to the manufacturer's technical documentation.



## FM Approved Solenoid valves

4010ES control units are assigned to FM Release Control Panel Group 3. Group 3 FM Approved Release Control units are compatible with all FM Approved Solenoid Valves rated at 22 Watts or less. For verification of agency listings and power requirements refer to the solenoid valve manufacturer's technical documentation.

## Suppression Release Peripheral Installation Reference Diagram

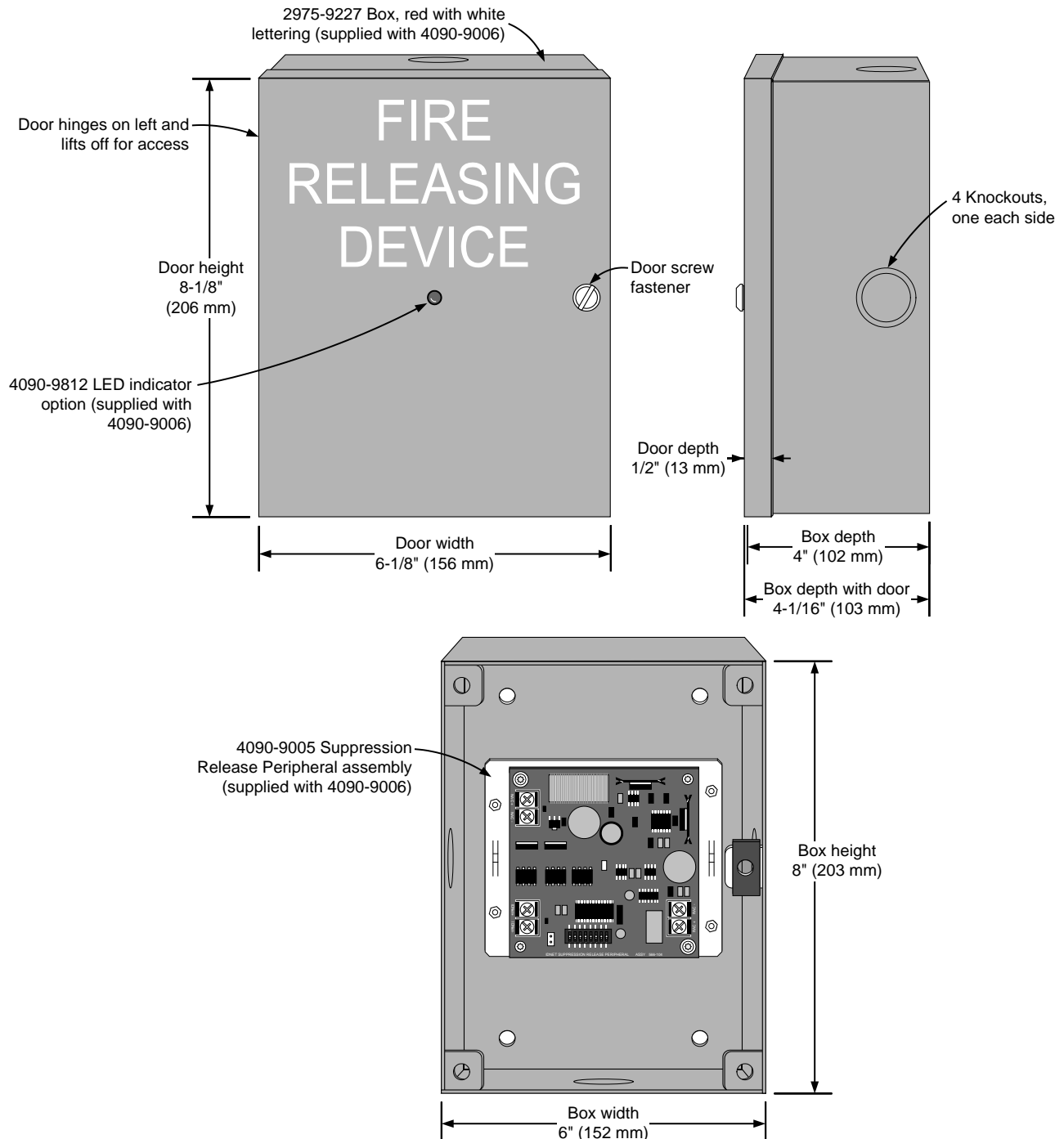

TYCO, SIMPLEX, and the product names listed in this material are marks and/or registered marks. Unauthorized use is strictly prohibited. NFPA 72 and National Fire Alarm and Signaling Code are registered trademarks of the National Fire Protection Association (NFPA).

